



泉州大昌纸品机械制造有限公司

QuanZhou DACHANG Paper Machinery Manufacturer Co.,LTD.

No.2,JianNan Hi-tech Industrial Park,Licheng District,QuanZhou,Fujian,China.(362000)

Tel: 86-595-22465662 Email:DACHANG@QZDACHANG.CN Web: WWW.QZDACHANG.CN

DCL-28 Full-auto Plastic Lid Applicator Machine

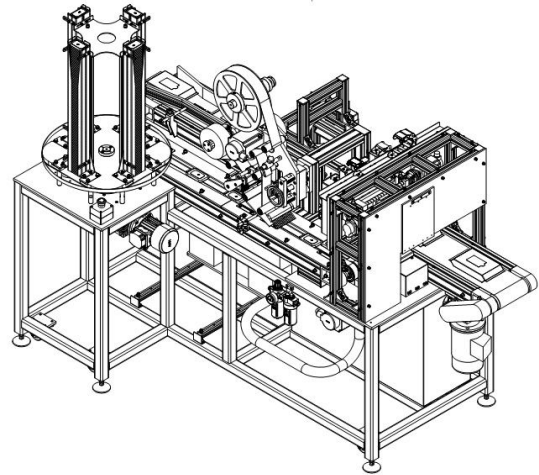

Video Link: <https://youtu.be/daj4Yz5BfVI>

I. Main Parameter:

1. Power supply: 380V 50HZ
2. Power: 9KW
3. Designed Speed: 60packs/min, stable production speed:45-55packs/min
4. Lid size(mm):wide \leq 80, Length \leq 120
5. Label: wide \leq 60, Length \leq 300
6. Material: Plastic cover and label, Hotmelt adhesive
7. Size of machine(mm): 2275*1311*1980(L*W*H)

II. Main Structure:

1. Four release slots, automatic switching.
2. Synchronous belt feeding mechanism.
3. A labeling machine, no cover automatically stop.
4. Double servo for taking cover and stick cover automatically.
5. Customized adhesive box.
6. Guide mechanism

III. Our Service:

Technical Support

1. Free consultant service, help customers to make project feasibility analysis.
2. We provide the relevant product information of the series for customer' s reference.
3. We offer the designing, installment drawing and necessary information for production according to customer' s real situation.
4. We inform the models, technical index and request, suppliers and reference price of all necessary raw materials for production.
5. We advise customers how to solve the usual machine fault.
6. We can supply the technicians to operate the machine.

After-sale Service

1. The machines are tested and have trial production in our factory before leaving our factory and they are shipped out only after the customers are satisfied with them.
2. When the machines are tested, our technicians will train the customers' technicians in theory and practice till they grasp the skills.
3. When the machines are delivered to the customers, we can go to customer' s factory to install, test the machines, and to train again before the operation staff start working.
4. During this period of one year warranty, if the machines were damaged by non-artificial reasons, we are responsible for repairing or changing parts.
5. During this period of warranty, if there is something wrong with the machine, we are responsible to provide project for solving this problem at the soonest, and help customers to restore production as soon as possible.
6. After the warranty, we charge only cost price for maintaining the machines within three years.
7. Other after-sale terms can be agreed by buyer and seller in addition.

DCL-28 Main Electrical Part

No.	Item	Model	Qty.	Brand	Mark
1	PLC	PS02A-AS332T	1pc	Delta	Baseplate
2	Omron Relay	G6B-4BND	2 pcs	Omron	
3	Solid state relay	SSR-25DA	1pc	FOTEX	
4	Air switch	3P-20A	1pc	Renming	
5		2P-10A	6pcs	Renming	
6	Switching power supply	NES-150-24	1pc	MW	
7	Converter	FR-D740-0.75K-CHT	1pc	Mitsubishi	
8	Servo driver	MR-J4-70A	2pcs	Mitsubishi	
9	Stepper driver	DV3722	3pcs	Dvision	
10	Visual controller	DMV2000-CL2-HS	1pc	Delta	
11	Guide rail		1pc	Own	

				manufactu rer	
12	Delta touch screen	DOP-B07S411	1pc	Delta	Panel
13	thermostat	AI-207-D2-L2	4pcs	Yudian	
14	Emergency stop switch	NB2-BS-544	4pcs	Renming	
15	Potentiometer	LA42DWQ-22 10k	1pc	Tianyi	
16	Delta Touch screen communication line	dvpcab215	1pc	Delta	
17	Photoelectric switch	ZD-L09N	3pcs	OPTEX	Main machine
18	camera	DMV-CM2MGCL	1pc	Delta	
19	Encoder	TRD-2T2000BF	1pc	Koyo	
20	Proximity switch	PR12-4DN	3pcs	Autonics	

DCL-28 Spare Parts List

No.	Item	Spec.	Qty
1	Adjustable hoof	M16*10* \varnothing 80	4 pcs
2	Toolbox	(Include box)	1pc
3	Encoder rubber ring		2 pcs
4	Heating pipe	Custom extended (350)	6 pcs
5	Heating pipe	Custom extended (200)	2 pcs
5	Suction cup		4 pcs

Machine details:

